



12 **NEW EUROPEAN PATENT SPECIFICATION**

45 Date of publication of the new patent specification : **01.02.95 Bulletin 95/05**

51 Int. Cl.⁶ : **G01N 33/49, // G01N35/08, G01N27/26**

21 Application number : **86109615.4**

22 Date of filing : **14.07.86**

54 **Blood analyzer.**

30 Priority : **22.07.85 US 757573**

43 Date of publication of application : **11.03.87 Bulletin 87/11**

45 Publication of the grant of the patent : **05.12.90 Bulletin 90/49**

45 Mention of the opposition decision : **01.02.95 Bulletin 95/05**

84 Designated Contracting States : **AT BE CH DE FR GB IT LI LU NL SE**

56 References cited :

EP-A- 0 084 874
EP-A- 0 098 550
US-A- 3 648 159
US-A- 3 648 160
US-A- 3 772 591
US-A- 3 997 838
US-A- 4 469 593
US-A- 4 484 135
US-A- 4 508 622

IEEE TRANSACTIONS ON BIOMEDICAL ENGINEERING, vol. BME-30, no. 3, March 1983, pages 141-154; E.D. TRAUTMAN et al.: "A practical analysis of the electrical conductivity of blood" Clinical Chemistry. 21/6. pp. 685-693, 1975.Veefkind et al.

73 Proprietor : **NOVA BIOMEDICAL CORPORATION**
200 Prospect Street
Waltham Massachusetts, 02254-9141 (US)

72 Inventor : **Young, Chung Chang**
145 Buckskin Drive
Weston, MA 02193 (US)
Inventor : **Coleman, Robert L.**
65 Indian Head Road
Framingham, MA 01701 (US)
Inventor : **Fleming, Sheila Marie**
125 Orange Street
Waltham, MA 02154 (US)
Inventor : **Grimes, John F.**
30 Fenelon Road
Framingham, MA 01701 (US)
Inventor : **Baumeister, Ferdinand**
One Winchester Street
Nashua, NH 03063 (US)
Inventor : **MacIndoe, Robert C., Jr.**
18 Prunier Street,
P.O.Box 299
Linwood, MA 01525 (US)
Inventor : **Catalano, Lou**
31 Frankland Road
Ashland, MA 01721 (US)
Inventor : **Coppola, Pat**
Five Cedar Street
Burlington, MA 01803 (US)
Inventor : **Spaziani, Fred**
41 Fair Oaks Drive
Lexington, MA 02173 (US)
Inventor : **Rodomista, Guy**
Nine Blueberry Hill Road
Natick, MA 01760 (US)
Inventor : **Fowler, James E.**
54 Barnard Avenue
Watertown, MA 02172 (US)

74 Representative : **Heidrich, Udo, Dr. jur.,**
Dipl.-Phys.
Rechtsanwalt & Patentanwalt
Dipl.-Phys. Dr. jur. U. HEIDRICH
Franziskanerstrasse 30
D-81669 München (DE)

EP 0 213 343 B2

BEST AVAILABLE COPY

Description

This invention relates to blood analyzers used to measure various components in a blood sample, e.g. in medical diagnosis and research.

5 The ratio of the volume of packed red blood cells from a whole blood sample to the total sample volume is useful measurement for diagnosing anemia and other disease conditions. The ratio is usually referred to as the "hematocrit ratio" or the "hematocrit value". It is usually determined by centrifuging a whole blood sample to separate cells from plasma.

10 It is known that, all other things being constant, the conductivity of a blood sample varies as a function of its hematocrit value, but other blood components, notably electrolytes, influence conductivity significantly, and the conductivity of those components must be accurately accounted for if a reliable hematocrit value is to be derived from conductivity readings.

US-A-3 648 159 (Stansell) discloses a portable system for electronically measuring blood ion levels and pH, including a miniature centrifuge for mechanically measuring hematocrit.

15 US-A-3 772 591 (Louder) and IEEE Trans. (BME-30) pp. 141-154 (March 1983) (Troutman) disclose measuring blood hematocrit by measuring conductance of various dilutions of the same blood sample.

US-A-3 997 838 (Shamos) discloses apparatus using an ion-selective electrode for determining the percentage volume of total particulates in a predetermined volume of sample of known ion concentration. E.g., percentage volume of total cells is determined for a whole blood sample by adding a predetermined volume of a diluent of known ion concentration, and then determining the liquid volume of the sample-diluent mixture.

20 EP 0 084 874 (Kiesewetter) discloses a hematocrit measuring device.

EP 0 098 550 (Hitachi) discloses a device for electronically measuring blood ion concentration and enzymatic activity.

25 Automated equipment for determining blood components, such as electrolyte concentration or dissolved blood gas partial pressures, often involve the use of electrodes positioned along a flow path. When whole blood is introduced in the flow path, the electrodes provides a reading of the desired blood characteristic.

Currently, electrodes are available to provide electrical signals representative of various blood components such as

30 sodium ion concentration " (Na^+) ",
potassium ion concentration " (K^+) ",
calcium ion concentration " (Ca^{++}) ",
hydrogen ion concentration "pH",
partial pressure attributed to O_2 (" PO_2 "), and
partial pressure attributed to CO_2 (" PCO_2 ").

35 From time to time it may be necessary to replace various components of a blood analyzer flow path, such as an electrode or a rubber inlet septum. Moreover, particularly in analyzers with a small, tortuous flow path having dead spots, whole blood may clot, resulting in lost time from shut-down, disassembly, cleaning, re-assembly, and re-starting of the apparatus.

40 The solution to the above-identified problem is accomplished by the method, apparatus and control solution kit of the present invention.

According to the invention a method for determining the hematocrit value of a blood sample by measuring sample conductivity has been developed, the method is characterized by

45 a) providing apparatus comprising a liquid flow path (Fig.2), means (115,116, Fig. 12) in said flow path for generating an electrical signal representative of the electrical conductivity of liquid in the path, and means (37,39,41) in the flow path for obtaining an electrical signal representative of the concentration of at least one ion species in liquid in said flow path;

50 b) introducing standardizing solution (pH_A , pH_B) in the flow path having a known concentration (Na_{STD}) of said ion species, and a conductivity representative of a known equivalent hematocrit value (H_A), obtaining a signal representative of said standardizing solution conductivity (R_A), obtaining a signal representative of said known ion species concentration (Na_{STD});

c) either before or after introducing the standardizing solution, introducing the sample in said flow path and obtaining an electrical signal representative of the sample conductivity (R_x) and an electrical signal representative of the sample ion-species concentration (Na_x);

55 d) deriving a tentative sample hematocrit value (H_x) responsive to the sample conductivity (R_x) signal, with reference to said standardizing conductivity (R_A) signal and said known standardizing equivalent hematocrit value (H_A); and

e) correcting said tentative sample hematocrit value (H_x) with reference to said sample and standardizing ion concentration signals and said known concentration (Na_{STD}) value (Figs. 2, 12, 13).

The invention encompasses also an apparatus (10) for determining hematocrit value in a blood sample comprising means for measuring the resistivity of said sample, characterized by

- 1) means for providing a fluid flow path (Fig. 2);
- 2) means (115, 116) in said flow path for providing an electrical signal representative of the conductivity of liquid passing along said flow path;
- 3) means (37, 39, 41) in said flow path for providing a signal representative of the concentration of an ion species in liquid passing along said flow path;
- 4) means (24) for introducing said blood sample into said flow path to obtain a signal representative of sample conductivity (R_x) and of sample ion species concentration (Na_x);
- 5) means (53, 53') for introducing into said flow path a standardizing solution having a known concentration (Na_{STD}) of an ion species and a conductivity representative of a known equivalent hematocrit value (H_A);
- 6) means (130) for deriving a signal representative of a tentative sample hematocrit value (H_x) from the sample conductivity (R_x) signal, with reference to the standardizing conductivity signal (R_A) and said standardizing equivalent hematocrit value (H_A); and
- 7) means (130) for correcting said tentative sample hematocrit value (H_x) with reference to said standardizing and sample ion concentration signals and said known standardizing ion concentration (Na_{STD}) (Figs. 2, 12, 13).

The use of a control solution kit for evaluating apparatus of any of Claims 10-13 has also been invented, that determines a tentative level for the hematocrit of blood sample by determining said sample conductivity (R_x) and correcting said tentative level with reference to a sample ion species concentration (Na_x) level, comprising an aqueous solution comprising said ion species and an ion activity enhancing agent, and having an ion activity corresponding to a known concentration of said ion and a conductivity representative of a known equivalent hematocrit value, said ion species concentration and said hematocrit value are within physiologically normal ranges.

The dependent claims specify the invention further.

The invention features, in one aspect, a method for determining the hematocrit value of a blood sample using sample conductivity.

The method is characterized by flowing the sample along a liquid flow path and using means in the flow path to obtain electrical signals representative of the sample's electrical conductivity and of the concentration of an ion species in the sample. Standardizing solution is introduced in the same flow path, either before or after the sample measurement. The standardizing solution has a known ion species concentration and a conductivity indicative of a known equivalent hematocrit value;

"equivalent" hematocrit value is used in this specification to mean the hematocrit level of a blood sample having a conductivity corresponding to that of the standardizing solution, even though the standardizing solution contains no whole blood cells and has an actual hematocrit value of 0.

Electrical signals are obtained for standardizing solution conductivity and ion species concentration.

A tentative sample hematocrit value is derived from the sample and standardizing conductivity signals, with reference to the known equivalent standardizing hematocrit value. Then the tentative hematocrit value is corrected with reference to the sample and standardizing ion concentration signals and to the known standardizing solution ion concentration value.

The invention also features, in another aspect, an apparatus for determining the hematocrit value in a blood sample by measuring the sample conductivity.

In a third aspect, the invention features the use of control solution kit for evaluating the hematocrit detection apparatus. The solution comprises an aqueous solution of the ion species (e.g. Na^+ or Cl^-) at a known concentration; and an ion activity enhancing agent (e.g. a polyol selected from glycerol and polyalkyl glycols). The solution has a conductivity representative of a known equivalent hematocrit level, and both the ion concentration and the equivalent hematocrit value preferably are within physiological ranges (e.g., $[Na^+]$ is between 130-150 mM, and hematocrit is between 40 and 55%).

The hematocrit measurement aspects of the invention provide rapid, accurate highly automated measurements of the hematocrit level, without the need for the analyzer user to store whole blood standards.

Other features and advantages of the invention will be apparent from the following description of the preferred embodiment and from the claims.

Description of the preferred embodiments

We first briefly describe the drawings.

I. Drawings

- Fig. 1 is a front view of a blood analyzer.
- 5 Fig. 2 is a diagrammatic representation of the fluid flow path and some of the electrical components of the analyzer of Fig. 1.
- Fig. 3 is a side view, in section, of the septum assembly and septum mounting plate of the analyzer of Fig. 1;
- Fig. 4 is a view along 4-4 of Fig. 5.
- Fig. 4A is a section of a septum from the septum assembly of Fig. 3.
- 10 Fig. 5 is an exploded view, with parts broken away, of the septum assembly and mounting plate of Fig. 3.
- Fig. 6 is a side view of the electrode holder assembly of the analyzer of Fig. 1.
- Fig. 7 is a view, in section, along 7-7 of Fig. 6.
- Fig. 8 is a side view of the holder assembly of Fig. 6 with parts exploded, broken away, and in section.
- Fig. 8A is a view of the reference block of the assembly of Fig. 6, taken along 8A-8A of Fig. 8.
- 15 Fig. 9 is a view along 9-9 of Fig. 8 with parts broken away and in section.
- Fig. 10 is a view, in section, along 10-10 of Fig. 8.
- Fig. 11 is a plan side view of an electrode clip for use in the assembly of Fig. 6.
- Fig. 12 is a diagrammatic representation of electronic components and functions related to the hematocrit detector of the analyzer of Fig. 1.
- 20 Fig. 12A is a graph of the reciprocal of resistivity versus $1/(1-\text{hematocrit value})$.
- Fig. 13 is a diagrammatic representation of the electrical functions of the analyzer of Fig. 1.

II. Structure

25 Analyzer 10 of Fig. 1 provides for measurement of the concentrations of certain electrolytes and gases in a small (e.g. less than about 0.25 ml) sample of whole blood that has been treated (e.g. with heparin) to prevent coagulation. Specifically, the treated sample is drawn from its container through a probe 20, along a sample flow path, and out a waste outlet 28 (Fig. 2). Readings of sample PO_2 , PCO_2 , $[\text{Na}^+]$, $[\text{K}^+]$, $[\text{Ca}^{++}]$, and pH are provided on a C.R.T. display 12 and a tape printer 14. The same flow path includes means to provide a measurement and reagent of the sample hematocrit value.

30 The above measurements are performed as described in greater detail below, using electrodes and associated components that yield an electric signal representative of the characteristic being measured. In order to ascribe a value to the signal, the electrodes are standardized periodically with standard gases from replaceable cylinders and with standard fluids from a replaceable fluid pack 18 whose components and operation are also described below. The operation of the electrodes and standardizing apparatus is controlled by a computer 35 13 (Fig. 13) in response to a control program and to the operator's entries on keypad 16.

A. Sample flow path

40 As illustrated in Fig. 2, probe 20 is a hollow elongated metal tube (e.g. stainless steel) having a fluid inlet 21 at one end and connected at the other end to a fluid flow path. A probe drive motor 22, controlled by controller 222, moves the probe longitudinally through septum assembly 24, while the probe outlet remains in communication with the fluid flow path. The furthest longitudinal extension of the probe in the direction of arrow A is shown in Fig. 2, with probe inlet 21 positioned outside the septum assembly, immersed in a sample 26 that is 45 to be drawn through the inlet and along the flow path.

Fig. 2 diagrams the sample flow path through an electrode assembly (best shown in Figs. 6-10 and described in greater detail below) that includes: a heater block 30 heated by a resistance heater 160; a series of six electrodes, 31, 33, 35, 37, 39, and 41 in an electrode block 80 that enable generation of signals representative of PO_2 , PCO_2 , pH, $[\text{Ca}^{++}]$, $[\text{K}^+]$, and $[\text{Na}^+]$, respectively; and a reference block 105. The external, mechanical configuration of the electrodes is described below; the electrochemical principles and composition of 50 the electrodes are conventional. From electrode block 80, the sample flows to waste outlet 28. The fluid flow is drawn along the path by a peristaltic pump 29, driven by stepper motor 230 under the control of controller 229.

55 Along the flow path, there are air detectors to sense conductivity changes representative of the change from air to liquid, thereby providing an indication of air/liquid transitions and thus to signal changes from one fluid to another and to verify sample and standard positioning. Specifically, one air detector 32 is positioned in heating block 30, and a detector 69 located in heater block 30 serves as a hematocrit level detector as described in greater detail below. A third air detector 103 is located in the electrode block. Finally, a clamp elec-

trode 43 is positioned upstream from waste outlet 28 to connect to circuitry that minimizes the common mode voltage range and thereby improves the sensitivity and stability of the electrode measurement.

B. Standard flow paths

5

The analyzer has been designed particularly to flow the various standard fluids through the flow path and to flush the flow path, while minimizing any opportunity for contamination between standards, or between a standard and a blood sample. As best shown in Fig. 2, the standards are assigned to specific flow paths and chambers in septum assembly 24, and from there, the standards flow through the above-described sample flow path to waste outlet 28. The various standards and their flow paths are:

10

1) G_A , which is a source of gas having known PO_2 and PCO_2 composition, connected via metering solenoid valves 46 (sold by Lee Company, Westbrook, Conn.) to a humidifier 47 and thence, via line 48 to chamber 49 of the septum assembly 24.

15

2) G_B , which is similar to G_A , having different PO_2 and PCO_2 composition, thereby enabling standardization of those two electrodes; G_B communicates with chamber 49 of septum assembly 24 via solenoid valves 46', humidifier 47' and line 48'.

3) pH_A , a liquid of known pH that flows via line 53 to chamber 54 of septum assembly 24;

20

4) pH_B , a standard similar to pH_A , having a pH different from that of pH_A , that flows via line 53' to septum assembly chamber 55. Standard pH_B has a total conductivity indicative of a known equivalent hematocrit value. As explained in greater detail below, a solution having a known conductivity can be treated as the equivalent of a whole blood sample having a specific "equivalent hematocrit value".

5) E_A , an electrolyte standard having a known $[Na^+]$, $[K^+]$, and $[Ca^{++}]$ and also having a total conductivity indicative of a known equivalent hematocrit value different from the value of pH_B ; E_A flows via line 56 to septum assembly chamber 57.

25

6) E_B , an electrolyte standard having a known $[Na^+]$, $[K^+]$, and $[Ca^{++}]$, different from those of E_A ; standard E_B flows via line 58 to septum assembly chamber 60.

The composition of the various standard solutions is given in more detail below.

30

Each of lines 53, 53', 56, and 58 flows through a pinch valve 51 that is controlled by D.C. motor 63, and controller 64 to shut those lines selectively and separately when they are not in use. Each of lines 53, 53', 56 and 58 flows through a preheater to warm the standard solutions somewhat before they enter the heating block 30. A flush line 61 bypasses pinch valve 51 and flows through preheater 52 to septum assembly chamber 62. Lines 48, 48', 61, 56, 58, 53, and 53' terminate in a rigid multi-plug connector 161 that is adapted to cooperate with the septum assembly 24 so that all of the lines can be connected simultaneously. Specifically, connector 161 is shaped to fit within recesses of the septum assembly surrounding each inlet to a septum assembly chamber and, when connector 161 is properly positioned, an outlet from each of the lines 48, 53, 53', 56, 58, and 61 removably seals to the appropriate septum inlet by overlapping it.

35

A high molarity reference solution (Ref) flows through line 67 where it contacts reference electrode 34, and from there into the above sample flow path between clamp electrode 43 and waste outlet 28. The use of an open reference junction (i.e., a junction that is not enclosed in a membrane) enables the use of a low pressure flow for reference solution, and thereby reduces any possibility of contamination of the sample flow path or the electrode sensors by reference solution. The dotted line 64 indicates the region of the analyzer bathed in air from heater 66 driven by fan 65 (connected to controller 66' and fan-fail monitor 65') to stabilize temperature.

40

Three specific features of the analyzer are discussed below in greater detail: septum assembly 24; electrode assembly 68 (Fig. 6); and hematocrit detection via conductivity detector 69.

45

C. Septum assembly

50

Referring to Figs. 3, 4, 4A, and 5, removable septum assembly 24 has chambers 49, 54, 55, 57, and 60, and 62 which are separated by rubber septa 70 (Fig. 3) that have been slit to receive probe 20 and to form a seal around the probe as it is extended through the assembly. The septum assembly enables the analyzer to automatically draw one or more of the reference fluids along the sample flow path without contamination of future samples. As best shown in Figs. 3, 4, 4A, and 5, the assembly includes an end mounting unit 71 and a plurality of central septa supports 72, each of which has a radial inlet 373 connecting with an axial central channel 74. A cylindrical rubber septum 70 seats in a cylindrical cavity 75 of the end mounting unit 71 and each central unit 72.

55

Fig. 4A shows a septum 70 in cross-section, free from the stresses it experiences in the assembly. Specifically, very small (e.g. .010") annular rims 70' around the periphery of each side of septum 70 are designed

so that, when the septum is seated, cavity 75 having a restrained diameter, it is subjected to moderate radial squeezing (arrow C) sealing at the ridge, so sealing is enhanced, and leakage around the probe is reduced. In this way, the septum design provides an adequate seal without the need for a tight fit that causes friction and wear as the probe moves.

5 The assembly is produced by aligning all of the units with unslit septa in place, and an external sleeve 77 is then placed over the sub-assembly. The assembly then is ultrasonically welded together. After ultrasonic welding, a knife is passed through the central channels 74 to form small slits in each septum 70. Because the septa are placed in alignment first, and then slit, the size of the slits can be minimized and alignment is ensured, to reduce wear on the septa from repeated movement of the probe through them, thereby lengthening the use-
10 ful life of assembly 24.

As the slits in septa 70 become worn, the seal between chambers in the assembly can be affected, and the possibility of contamination is increased, so that it is necessary to replace the septum assembly from time to time. To facilitate removal of the assembly from the analyzer, end unit 71 is designed to rotatably engage and disengage a spring-loaded latch on mounting plate 163 of analyzer 10 as shown in Fig. 5. Specifically, a
15 cylindrical recess 76 on plate 163 the face of analyzer 10 includes two thick, resilient parallel wires 373, spaced apart at a preset distance. End unit 71 of assembly 24 includes two seating posts 78 that have parallel flat sides 80 positioned to fit between wires 373. Two flanges 381 of posts 78 are generally flat, with slightly rounded corners, and define generally straight parallel grooves 82 spaced apart a distance that is very slightly less than the distance between wires 373. To insert the septum assembly, its end 71 is inserted in recess 76 in an
20 initial position with sides 80 parallel to, and positioned between, wires 373, and then the assembly is rotated in either direction to engage wires 373 in grooves 82. At 1/8 turn, the wires are resiliently forced apart by the shoulders of grooves 82 creating a position of instability such that, a slight movement away from the 1/8 turn position will release the biasing force of the wires to re-establish a stable position. At 1/4 turn from the initial position, the wires seat in the grooves and lock the assembly in place. A 1/4 turn in either direction releases
25 the assembly.

Once assembly 24 is inserted, manifold connector 161 is forced into place so that each of the various standardizing lines sealingly overlaps the proper inlet on the septum assembly as shown in Fig. 4.

D. Electrode assembly

30 The fluid flow path exiting the probe communicates with an electrode assembly shown in Figs. 6-11. The path enters heating block 30 through inlet 101 (Fig. 10) and follows a circuitous route through stainless steel tubing to allow heat transfer from the heating block. Block 30 includes air detector 32 having a pair of electrodes
35 102 that are spaced apart in a chamber having passivated (e.g. HNO₃ etched stainless steel) walls. Electrodes 102 are connected to a reflected impedance detector that is driven by an AC source and generates a signal to be converted to digital signal to control the probe via computer 130 (Fig. 13). From air detector 32, the fluid passes to hematocrit detector 69, described in greater detail below.

As shown in Fig. 8, the connection between heater block 30 and electrode block 80 is formed by a small piece of Tygon (TM Norton Co., Worcester, Mass.) tubing 151 that fits over the ends of stainless steel tubing
40 from the flow path of each block; the Tygon tubing fits within countersinks in the respective blocks surrounding the ends of the stainless tubing. In electrode block 80, the flow path passes over each of electrodes 31, 33, 35, 37, 39, and 41 (Fig. 2) in sequence. Air detector 103 (Fig. 2), which is positioned between electrode 33 and electrode 35, operates as described above regarding detector 32. As shown in Fig. 9, the flow path follows a zig-zag path between wells at the bottom of cylindrical electrode cavities 104 in block 80.

45 The downstream component of the electrode assembly is a reference block 105 which includes clamp electrode 43 (Fig. 2) and a T connection upstream from it, connecting to reference line 67, allowing reference fluid (Ref.) to be drawn out waste outlet 28. The reference electrode 34 in line 67 serves as a reference for electrodes 35, 37, 39, and 41, (the pH, [Ca⁺⁺], [K⁺], and [Na⁺] electrodes). The two gas electrodes 31 and 33 have internal references.

50 The flow path has a relatively narrow diameter (e.g. 0.7 mm), and is tortuous as shown in Fig. 9, and therefore clots may form in the path. Conveniently, heater block 30, electrode block 80, and reference block 105 are separate units that can be disassembled and replaced individually, as shown in Fig. 8, when it is necessary to replace one of them or to clean a blood clot from them. Specifically, heater block 30 includes a back plate 106 to which electrode block 80 is bolted. A lipped retainer 107 screws into the top edge of plate 106 and grips
55 a notch in the top of reference block 105; and a lip 108 on the bottom of the rear face of reference block 105 engages a groove in the top of electrode block 80. Electrical connections to the heaters and air detectors of block 30 are made through multi-pin connector 44. Connections to the electrical components of blocks 80 and 105 are made through male connector plugs that allow easy separation of the units. A locator pin 152 extends

rearwardly from plate 106 to guide the electrode assembly as it is forced in the direction of arrow B (Fig. 8) into a cooperatively shaped recess in the analyzer. A flow path inlet 109, a reference inlet 110 (Fig. 9), and waste outlet 28 extend from the assembly to be connected to tubing in the analyzer.

It is particularly advantageous that the entire fluid flow path of the electrode assembly (i.e. through the heater, the electrodes and the reference block) can be readily removed and replaced in a short time, removing only two bolts. In that way, when a part of the flow path becomes defective, the flow path can be replaced with an alternate part and the apparatus can be restarted without taking time to cure the defect in the original part. Thus downtime on the apparatus can be significantly reduced merely by maintaining spare flow path parts.

Each of electrodes 31, 33, 35, 37, 39, and 41 is mounted on an individually replaceable unit, one of which (electrode unit 31') is shown in Fig. 11. Electrode unit 31' consists of an electrode-carrying cylinder 89 movably inserted through an opening 83 in the back 82 of a clip 81. Clip 381 has a resiliently deflectable ridge 85 extending from one end, which terminates in a latch 86 sized to engage a groove 87 in block 80. A guide pin 88 extending from clip 381, at the end opposite to latch 85, fits in opening 45 in block 80. Cylinder 89 has a diameter small enough to fit easily within opening 83, and a compression spring 90 is seated between clip 81 and a flange on the cylinder, thus biasing the cylinder into an electrode cavity 104 in block 80. A flange 153 on the rear of cylinder 89 prevents the cylinder from passing through the clip opening 83. The PCO₂ electrode 31 is bonded to cylinder 89, and cylinder 89 is hollow to accommodate wiring and (because it is a gas electrode with an internal reference) a reference electrode that electrically connects the electrode to signal-generating apparatus via plug 91.

E. Hematocrit value detector

The apparatus provides a rapid, accurate hematocrit-value determination, electronically, without time-consuming, labor intensive centrifuging and visual measurement and without using a whole blood standard. The hematocrit value determination is based on the relationship between a blood sample's electrical conductivity (C) and its hematocrit value (H), which is given the expression

$$C = C_0 (1 - H) \quad (1)$$

where C₀ is the conductivity when H=0. The blood analyzer determines the conductivity of the sample by obtaining a resistance signal and comparing it to resistance signals from two reference solutions, each having a different known conductivity. The analyzer includes electrical components to provide a linear signal-to-resistivity relationship in the area of interest, so that the two references are sufficient to establish a value corresponding to the sample resistivity signal.

The electrical conductivity of a blood sample depends on a number of factors in addition to the hematocrit value, notably concentrations of various electrolytes, so any conversion of standard fluid conductivity to hematocrit value necessarily implies concentration levels for such electrolytes. The sample electrolyte concentration may vary enough from those implied standard concentrations to require correction; however, it has been found that, if the sodium concentration implied in the standard is used to correct the actual sample conductivity, the hematocrit value obtained will be accurate within the ranges necessary for blood hematocrit measurements.

In general, assuming a given [Na⁺] level and given detector geometry, the resistance (R_x) is related to hematocrit value as shown in Fig. 12A, where R₀ is the resistance at H=0. Thus, R_x can be used to obtain the hematocrit value (H_x) of a blood sample using the known resistance (R_A) and known hematocrit value (H_A) of a standard A by the following equation:

$$R_x - R_A = R_0 [1/(1 - H_x) - 1/(1 - H_A)] \quad (2)$$

where R₀ is the resistance at H=0.

In order to determine R₀, a second standard having a known equivalent hematocrit value (H_B) is needed. One of the pH standards, e.g. pH_B, is preferably used for this purpose. By measuring the resistance (R_B) of pH_B and the resistance (R_A) of E_A, R₀ can be determined from equation (2). Once R₀ is known, and R_x and R_A can be measured, and the sample hematocrit (H_x) can be obtained by rearranging equation (2), H_A being known also:

$$1/(1 - H_x) = 1/(1 - H_A) + (R_x - R_A)/R_0 \quad (3)$$

The equivalent hematocrit values of the standards can be determined by standardizing them to actual whole blood standards.

To correct for variations in resistance attributed to variations in [Na⁺], the true sample hematocrit value (H_x^{*}) can be obtained from H_x using the following relationship:

$$1/(1 - H_x^*) = 1/(1 - H_x) * (Na_x/Na_{STD}) \quad (4)$$

where Na_{STD} is the [Na⁺] in standard E_A and Na_x is the sample [Na⁺].

When operating the analyzer, it is highly desirable to use an external control to confirm the accuracy of the instrument. The external control could be a whole blood sample having very precisely known electrolyte, pH, blood gas and hematocrit levels. However, whole blood is relatively expensive and difficult to handle because it has a short shelf life and is relatively unstable.

For this reason, it is desirable to use a surrogate solution that mimics whole blood sufficiently to serve as a satisfactory control. A stable aqueous buffer having known electrolyte and pH could serve as a control for all readings other than hematocrit. The difficulty in using such a buffer as a hematocrit level control lies in the fact that, at normal physiological ranges, the sodium ion concentration is about 130 mM-150 mM. The conductivity of such a solution provides an equivalent hematocrit value of less than 5%, which is far below the normal range of about 50%.

It is highly desirable to have the equivalent hematocrit value of the control in normal ranges, in part because of the limitations on the linear signal-to-resistance range of the analyzer circuitry. One could try to raise the equivalent hematocrit level of the control by reducing its $[Na^+]$, but in so doing, the $[Na^+]$ would have to be drastically reduced and therefore the correction required by equation (4) would largely counterbalance any effective increase in the corrected hematocrit value.

This dilemma is resolved by adding an ion activity coefficient enhancer to the aqueous control solution in order to increase the ion activity measured by the $[Na^+]$ sensing electrode and to increase the resistance measured by the hematocrit resistance detector. By including such an enhancer in the control solution, the actual $[Na^+]$ may remain well below physiological levels, but the $[Na^+]$ sensing electrode measures ion activity, and the increased Na^+ activity coefficient resulting from the presence of the enhancer will provide a signal equivalent to a physiological $[Na^+]$; thus, the $[Na^+]$ correction resulting from equation (4) will not affect the control hematocrit significantly.

Suitable activity coefficient enhancers are polar, water-miscible organic compounds, particularly polyols such as polyethylene glycol, glycerol, and polypropylene glycol. It is possible, using such activity enhancers, to formulate control solutions with $[Na^+]$ in the normal range (130 mM-150 mM) and with conductivities characteristic of a sample having a normal hematocrit (40%-55%).

Suitable control solutions have a $[Na^+]$ of 20-60 mM, $[K^+]$ of 0.5 mM-1.7 mM, $[Ca^{++}]$ of 0.1-0.5 mM, pH of 6.8-7.6 and between 10% and 50% (V/V) of an enhancer such as glycerol. Two specific such control solutions are:

30

	Control #1	Control #2
	$[Na^+]$ = 52 mM	$[Na^+]$ = 24 mM
	$[K^+]$ = 1.5 mM	$[K^+]$ = 0.7 mM
	$[Ca^{++}]$ = 0.46 mM	$[Ca^{++}]$ = 0.2 mM
	pH = 7.46	pH = 7.46
	glycerol = 38% (V/V)	glycerol = 17% (V/V)

35

Suitable pH standards are buffered solutions exemplified by the following:

40

pH _A :	KH ₂ PO ₄	8.695 mM
	Na ₂ HPO ₄	30.430 mM
	NaHCO ₃	0.1040 mM
	final pH=7.384	

45

pH _B :	KH ₂ PO ₄	25 mM
	Na ₂ HPO ₄	25 mM
	final pH=6.840	
	$[Na^+]$ =30—70 mM	950 preferred)

50

Suitable electrolyte standards are exemplified by the following:

E_A: $[Na^+]$ =120-160 mM (140.0 preferred); $[K^+]$ =4.00 mM;
 $[Ca^{++}]$ =1.00 mM

55 E_B: $[Na^+]$ =75.0 mM; $[K^+]$ =20.0 mM;
 $[Ca^{++}]$ =2.00

Suitable gas standards have between 0-25% O₂ and 0-15% CO₂, the balance being N₂.

Suitable Ref. and flush solutions are well known to those in the art.

Referring to Fig. 12, as a solution passes through hematocrit detector 69, the resistance between electrodes 115 and 116 is measured through a reflected impedance technique in a constant current AC circuit that communicates with electrodes 115 and 116 via transformers 120 and 121. A resistor R_1 (typically about 20 K ohm) is selected for stability, e.g. to avoid positive feedback due to phase shift from the boundary layer capacitance at the electrodes. The winding ratio on transformer 120 is 1:1, and the winding ratio on transformer 121 is 25:1. The circuitry isolates the AC excitation means and the measuring means from the electrodes, avoiding direct connections, d.c. polarizing effects, and providing the ability to function over a relatively large common mode voltage range at the electrodes. The circuitry also provides a linear signal-to-resistivity relationship over a relatively large range.

As shown more specifically in Fig. 12, a 900 hz constant voltage A/C source 118 is connected to the drive coil of transformer 120. The other coil of transformer 120 is connected to electrode 115 of detector 69. Electrode 116 is connected through resistor R_1 to the drive coil of transformer 121 to complete the loop 210 from which electrode impedance is to be communicated to the constant current AC circuit. Transformer 121 provides feedback to maintain constant current in the impedance measuring circuit. The resulting signal from the constant circuit, reflected impedance detecting circuitry, is connected to multiplexer 183 via filtered output, full-wave rectifier 181, and non-inverting amplifier 182. The following table provides values and part numbers for the schematically illustrated components.

TABLE 1

Component	Value or part No.
R_1	20K ohm
R_2	20K ohm
R_3	300K ohm
R_4	1M ohm
R_5	100K ohm
R_6	1M ohm
C_1	.0022 micro farad
C_2	10 micro farad
C_3	0.1 micro farad
C_4	0.1 micro farad
C_5	0.1 micro farad
D_1	HLMP-1301 (Hewlett Packard)
D_2	HLMP-1301 (Hewlett Packard)
D_3	1N 821 A
A_1	TL074C (Texas Instrument)
Transformer 120	SP-66 (Triad)
Transformer 121	SP-48 (Triad)

As also shown in Fig. 12, sodium electrode 41 and reference electrode 34 are connected to differential amplifier 190 to provide a signal representative of $[Na^+]$ to multiplexer 183. A selector 191 selects an input signal (e.g. from amplifier 190, amplifier 182, or other circuitry not shown) to be output, through filter 187 and analog-to-digital converter 188, to computer 130, an Intel SBC 80/10B computer comprising an 8080A CPU microprocessor.

First the standardizing solutions E_A and E_B are circulated through the flow path, and computer 130 stores signals representing their respective conductivities and $[Na^+]$, as well as the H_A , H_B , and Na_{STD} values. When values for R_A and R_B have been determined, together with the known H_A , H_B , and Na_{STD} values, then the corrected sample hematocrit H_x^* can be derived by measuring R_x and Na_x , using computer 130 to perform the above calculations. A suitable program in assembly language for performing these calculations on the 8080A CPU microprocessor is included as an appendix to this application. In the program the hematocrit value is referred to as (H_c) .

III. Operation

The analyzer is used to measure characteristics of a blood sample. After the apparatus is turned on, the various heaters and blowers are allowed to equilibrate and pump 29 is activated to create suction through the sample flow path and reference solution is pumped through reference line 67. In order to flush the flow path, the probe is retracted by drive motor 22, so that its inlet opening 21 is positioned in the flush-fluid chamber of septum assembly 24. Flush fluid therefore is drawn through the flow path and out the waste outlet 28, cleaning the flow path.

When the analyzer is idle, pump 29 is controlled to maintain a gas/liquid interface at detector 103, thereby maintaining the electrolyte and pH electrodes in a liquid environment while maintaining the PCO_2 and PO_2 electrodes in a gas environment.

To standardize the electrodes the probe inlet is introduced sequentially, under the control of computer 130 and motor 22, into each septum assembly cavity; with the probe positioned in a given cavity, the computer 130 controls pinch valve motor control 64 or solenoid valves 46 and 46' to open the desired standard fluid (liquid or gas) to the septum assembly. Other standards are sealed by pinch valve 51 and solenoid valves 46 and 46', to provide additional assurance against contamination. Standardizing with liquids E_A , E_B , pH_A , and pH_B is accomplished by flowing a standard through the flow path and then holding it there by appropriate control of pump 29 in response to liquid positions indicated by the air detectors. Standardizing with G_A and G_B is accomplished by flowing those standards along the flow path. Electrical signal values for each standard are recorded and stored by storage means in computer 130 for later comparison with sample signal values. Valves 46 and 46' each comprise dual solenoid valves to allow a metered flow of standardizing gas under the control of computer 130.

Standardization being complete, when analysis is required, the probe is fully extended to draw sample solution through the flow path, without contamination from standards. Signals representative of each measured sample characteristic are generated and transferred to computer 130 for comparison with standard signals thus establishing a value for each characteristic that is fed to output apparatus-i.e., C.R.T. display 12 and tape print-out 14. With the exception of the hematocrit measurement, the details of the apparatus for generating standard and sample signals, for comparing those signals, and for calculating values for sample characteristics are well known and need not be repeated here.

Fig. 13 shows other aspects of the electronic components and their connection to computer 130. Specifically, in Fig. 13, inputs to computer 130 are provided from keypad 16 and from multiplexer 183 via filter 187 and A/D converter 188. The computer provides output to probe motor control 222, pinch valve motor controller 64, sample preheater controller 160', air heater and blower controller 66', and solenoid valves 46 and 46'. Also, computer 130 provides output to CRT screen 12 and printer 14.

Other embodiments

Other embodiments are within the following claim. For example, other blood components or additional blood components can be sensed by the analyzer. Other electrolytes such as $[\text{Cl}^-]$ can be used as a surrogate for hematocrit. In that case, suitable $[\text{Cl}^-]$ concentrations of standardizing solutions E_A and E_B are 110 mM and 60 mM, respectively. In that case, 41 in Fig. 12A would be a $[\text{Cl}^-]$ sensing electrode. In place of the electrode isolating circuitry described above, the electrodes could be directly coupled to an AC conductivity measuring circuit with a local ground (e.g. in the preheater).

Claims

1. Method for determining the hematocrit value of a blood sample by measuring sample conductivity, characterized by
 - a) providing apparatus comprising a liquid flow path (Fig.2), means (115,116, Fig. 12) in said flow path for generating an electrical signal representative of the electrical conductivity of liquid in the path, and means (37, 39,41) in the flow path for obtaining an electrical signal representative of the concentration of at least one ion species in liquid in said flow path;
 - b) introducing standardizing solution (pH_A , pH_B) in the flow path having a known concentration (Na_{STD}) of said ion species and a conductivity representative of a known equivalent hematocrit value (H_A), obtaining a signal representative of said standardizing solution conductivity (R_A), obtaining a signal representative of said known ion species concentration (Na_{STD});
 - c) either before or after introducing the standardizing solution, introducing the sample in said flow path

- and obtaining an electrical signal representative of the sample conductivity (R_x) and an electrical signal representative of the sample ion-species concentration (Na_x);
- d) deriving a tentative sample hematocrit value (H_x) responsive to the sample conductivity (R_x) signal, with reference to said standardizing conductivity (R_A) signal and said known standardizing equivalent hematocrit value (H_A); and
- 5 e) correcting said tentative sample hematocrit value (H_x) with reference to said sample and standardizing ion concentration signals and said known ion concentration (Na_{STD}) value (Figs. 2, 12, 13).
2. Method of Claim 1, characterized by providing, from time to time, an external validation of said apparatus by introducing in said flow path a control solution having an ion activity corresponding to a known ion species concentration, and a conductivity representative of a known equivalent hematocrit level, said ion species concentration and said hematocrit level are within physiologically normal ranges.
- 10 3. Method of Claim 2, characterized in that said control solution comprises an ion activity enhancing agent.
- 15 4. Method of Claim 3, characterized in that said ion activity enhancing agent is a polyol.
5. Method of Claim 4, characterized in that said polyol is selected from glycerol and polyalkyl glycols.
6. Method of Claim 1 or 2, characterized in that said conductivity obtaining step comprises:
- 20 a) providing electrodes (115, 116) in said flow path coupled to a constant current AC circuit (118) with transformer (120, 121);
- b) applying an AC signal to said electrodes (115, 116) from said circuit (118) via said transformer (120, 121); and
- 25 c) detecting impedance reflected in said AC circuit (118) (Fig. 12).
7. Method of Claim 1 or 2, characterized by performing the following steps in any order:
- a) obtaining said electrical signals representative of standardizing conductivity (R_A) and standardizing ion concentration (Na_{STD});
- 30 b) storing signals representative of said known standardizing equivalent hematocrit value (H_A) and said known standardizing ion concentration (Na_{STD}) value;
- c) obtaining said electrical signals representative of sample ion concentration (Na_x) and standardizing ion concentration (Na_{STD});
- d) comparing said sample and said standardizing ion concentration signals with reference to said stored known standardizing concentration (Na_{STD}) value signal to derive a signal representative of sample ion concentration (Na_x) value;
- 35 e) comparing said sample and said standardizing conductivity signals with reference to said stored standardizing hematocrit value (H_A) signal to derive a signal representative of said tentative sample hematocrit value (H_x);
- 40 f) correcting said tentative sample hematocrit value (H_x) signal with reference to said sample ion concentration (Na_x) signal and said stored standardizing ion concentration (Na_{STD}) value signal.
8. Method of any preceding Claim, characterized in that said ion species is Na^+ or Cl^- .
9. Apparatus (10) for determining hematocrit value in a blood sample comprising means for measuring the resistivity of said sample, characterized by
- 45 1) means for providing a fluid flow path (Fig. 2);
- 2) means (115, 116) in said flow path for providing an electrical signal representative of the conductivity of liquid passing along said flow path;
- 3) means (37, 39, 41) in said flow path for providing a signal representative of the concentration of an ion species in liquid passing along said flow path;
- 50 4) means (24) for introducing said blood sample into said flow path to obtain a signal representative of sample conductivity (R_x) and of sample ion species concentration (Na_x);
- 5) means (53, 53') for introducing into said flow path a standardizing solution having a known concentration (Na_{STD}) of an ion species and a conductivity representative of a known equivalent hematocrit value (H_A);
- 55 6) means (130) for deriving a signal representative of a tentative sample hematocrit value (H_x) from the sample conductivity (R_x) signal, with reference to the standardizing conductivity signal (R_A) and said standardizing equivalent hematocrit value (H_A); and

- 7) means (130) for correcting said tentative sample hematocrit value (H_x) with reference to said standardizing and sample ion concentration signals and said known standardizing ion concentration (Na_{STD}) (Figs. 2, 12, 13).
- 5 10. Apparatus of Claim 9, characterized by means for storing either said sample or said standardizing conductivity signal, and means for comparing said conductivity signals with reference to said known standardizing equivalent hematocrit value (H_A) to generate a signal representative of said tentative sample hematocrit value (H_x).
- 10 11. Apparatus of Claim 10, characterized in that said means (130) for correcting said tentative sample hematocrit value (H_x) signal comprises means for storing either said standardizing or said sample ion concentration signal and comparing said concentration signals with reference to said known standardizing ion concentration (Na_{STD}) value.
- 15 12. Apparatus of Claim 9, characterized by at least two standardizing solutions (pH_A , pH_B), each of which has a conductivity indicative of a known equivalent hematocrit value (H_A) and a known ion concentration (Na_{STD}).
13. Apparatus of Claim 9, characterized in that said ion species is Na^+ or Cl^- .
- 20 14. Apparatus of Claim 9, characterized in that said conductivity-signal generating means comprises: electrodes (115,116) in said flow path; a constant current AC circuit (118) coupled to said electrodes (115, 116) via a transformer (120, 121), and means for detecting reflected impedance in said AC circuit (118) (Fig. 12).
- 25 15. Apparatus of Claim 14, characterized in that said conductivity-signal generating means comprises:
 1) a first transformer (120) for coupling said AC circuit (118) to said electrodes (115, 116);
 2) a second transformer (121) for maintaining constant current in said AC circuit (118); and
 3) means (210) establishing a loop, connected between said electrodes (115, 116), and comprising
 30 means connected between said electrodes (115,116) and said second transformer (121) to compensate for means connected between said electrodes (115, 116) and said second transformer (121) to compensate for inherent capacitance at the electrode/sample interface (Fig. 12).
- 35 16. Apparatus of Claim 15, characterized in that said means for providing a signal of the concentration of an ion species comprises an ion-species-sensitive electrode (37, 39, 41) positioned in said flow path and connected via an electrical circuit to the input of a multiplexer (183), said impedance detecting means also being connected to the input of said multiplexer (183), said multiplexer (183) having an output means connected via an analog-to-digital converter (188) to a means (130) for storing and comparing signals, and to said means (130) for correcting sample conductivity (Fig. 12).
- 40 17. **Use of Control solution Kit**
 for evaluating apparatus of any of claims 10 - 13,
 - that determines a tentative level for the hematocrit of a blood sample by
 - determining said sample conductivity (R_x) and
 - correcting said tentative level with reference to a sample ion species concentration (Na_x) level,
 45 *comprising*
 - an aqueous solution
comprising
 - said ion species and
 - an ion activity enhancing agent, and having
 50 - an ion activity corresponding to a known concentration of said ion and
 - a conductivity representative of a known equivalent hematocrit value,
 - said ion species concentration and said hematocrit value are
 - within physiologically normal ranges.
- 55 18. **Use of claim 17,**
characterized in that
 - said ion species is
 - Na^+ or Cl^- .

19. Use of claim 17 or 18,
characterized in that
- said ion activity enhancing agent is
- a polyol.

5

20. Use of claim 19,
characterized in that
- said polyol is selected from
- glycerol and polyalkyl glycols.

10

Patentansprüche

1. Verfahren zur Bestimmung des Hämatokrit-Werts einer Blutprobe durch Messen der Proben-Leitfähigkeit, gekennzeichnet durch
- 15 a) Vorsehen einer Vorrichtung mit einem Flüssigkeits-Strömungsweg (Fig. 2), einer Einrichtung (115, 116, Fig. 12) im Strömungsweg zum Erzeugen eines elektrischen Signals entsprechend der elektrischen Leitfähigkeit der Flüssigkeit im Strömungsweg, und einer Einrichtung (37, 39, 41) im Strömungsweg zur Gewinnung eines elektrischen Signals entsprechend der Konzentration mindestens einer Ionenart in der Flüssigkeit im Strömungsweg;
- 20 b) Einleiten in den Strömungsweg einer Standard-Lösung (pH_A , pH_B) einer bekannten Konzentration (Na_{STD}) der Ionenart und einer Leitfähigkeit entsprechend einem bekannten Äquivalent-Hämatokritwert (H_A), Gewinnen eines Signals entsprechend der Standard-Lösungs-Leitfähigkeit (R_A), Gewinnen eines Signals entsprechend der bekannten Ionenart-Konzentration (Na_{STD});
- 25 c) entweder vor oder nach Einleiten der Standard-Lösung, Einleiten der Probe in den Strömungsweg und Gewinnen eines elektrischen Signals entsprechend der Proben-Leitfähigkeit (R_x) und eines elektrischen Signals entsprechend der Proben-Ionenart-Konzentration (Na_x);
- d) Ableiten eines vorläufigen Proben-Hämatokritwerts (H_x) abhängig vom Proben-Leitfähigkeits (R_x)-Signal, bezüglich dem Standard-Leitfähigkeits (R_A)-Signal und dem bekannten Standard-Äquivalent-Hämatokritwert (H_A); und
- 30 e) Abgleichen des vorläufigen Proben-Hämatokritwerts (H_x) bezüglich dem Proben- und dem Standard-Ionenkonzentrations-Signal und dem bekannten Ionenkonzentrations (Na_{STD})-Wert (Fig. 2, 12, 13).
- 35 2. Verfahren nach Anspruch 1, gekennzeichnet durch von Zeit zu Zeit äußeres Überprüfen der Vorrichtung durch Einleiten in den Strömungsweg einer Kontroll-Lösung mit einer Ionenaktivität entsprechend einer bekannten Ionenart-Konzentration, und einer Leitfähigkeit entsprechend einem bekannten Äquivalent-Hämatokritwert, wobei die Ionenart-Konzentration und der Hämatokritwert in physiologisch normalen Bereichen liegen.
- 40 3. Verfahren nach Anspruch 2, gekennzeichnet dadurch, daß die Kontroll-Lösung einen Ionenaktivitäts-Verstärker besitzt.
4. Verfahren nach Anspruch 3, gekennzeichnet dadurch, daß der Ionenaktivitäts-Verstärker ein Polyol ist.
- 45 5. Verfahren nach Anspruch 4, gekennzeichnet dadurch, daß das Polyol ausgewählt ist aus Glycerin (1,2,3-Propantriol) und Polyalkyl-Ethylenglykol (1,2-Ethandiol, "Glykol").
6. Verfahren nach Anspruch 1 oder 2, gekennzeichnet dadurch, daß der Schritt zur Leitfähigkeits-Ermittlung vorsieht
- 50 a) Vorsehen von Elektroden (115, 116) im Strömungsweg, gekoppelt an eine Konstantstrom-Wechselspannungs-Schaltung (118) über einen Übertrager (120, 121);
- b) Anlegen eines Wechselspannungs-Signals an die Elektroden (115, 116) von der Schaltung (118) über den Übertrager (120, 121); und
- c) Erfassen der Impedanz der Wechselspannungs-Schaltung (118) (Fig. 12).
- 55 7. Verfahren nach Anspruch 1 oder 2, gekennzeichnet durch folgende Schritte in beliebiger Folge:
- a) Gewinnen der elektrischen Signale entsprechend der Standard-Leitfähigkeit (R_A) und der Standard-Ionenkonzentration (Na_{STD});

- b) Speichern von Signalen entsprechend dem bekannten Standard-Äquivalent-Hämatokritwert (H_A) und dem bekannten Standard-Ionenkonzentrations (Na_{STD})-Wert;
- c) Gewinnen der elektrischen Signale entsprechend der Proben-Ionenkonzentration (Na_x) und der Standard-Ionenkonzentration (Na_{STD});
- 5 d) Vergleichen des Proben- und des Standard-Ionenkonzentrations-Signals mit dem gespeicherten bekannten Standard-Konzentrations (Na_{STD})-Wert-Signal zum Gewinnen eines Signals entsprechend dem Proben-Ionen-Konzentrations (Na_x)-Wert;
- e) Vergleichen des Proben- und des Standard-Leitfähigkeits-Signals mit dem gespeicherten Standard-Hämatokritwert (H_A)-Signal zum Gewinnen eines Signals entsprechend dem vorläufigen Proben-Hämatokritwert (H_x);
- 10 f) Abgleichen des vorläufigen Proben-Hämatokritwert (H_x)-Signals bezüglich dem Proben-Ionenkonzentrations (Na_x)-Signal und dem gespeicherten Standard-Ionenkonzentrations (Na_{STD})-Wert-Signal.
8. Verfahren nach einem der vorhergehenden Ansprüche, gekennzeichnet dadurch, daß die Ionenart Na^+ oder Cl^- ist.
- 15 9. Vorrichtung (10) zur Bestimmung des Hämatokrit-Werts in einer Blutprobe mit einer Einrichtung zum Messen des spezifischen Widerstands der Probe, gekennzeichnet durch
- 1) eine Einrichtung zur Vorgabe eines Fluid-Strömungswegs (Fig. 2);
- 20 2) eine Einrichtung (115, 116) im Strömungsweg zur Abgabe eines elektrischen Signals entsprechend der Leitfähigkeit der Flüssigkeit im Strömungsweg;
- 3) eine Einrichtung (37, 39, 41) im Strömungsweg zur Abgabe eines Signals entsprechend der Konzentration einer Ionenart in der Flüssigkeit im Strömungsweg;
- 4) eine Einrichtung (24) zum Einführen der Blut-Probe in den Strömungsweg zum Gewinnen eines Signals entsprechend einer Proben-Leitfähigkeit (R_x) und einer Proben-Ionenart-Konzentration (Na_x);
- 25 5) eine Einrichtung (53, 53') zum Einleiten in den Strömungsweg einer Standard-Lösung mit einer bekannten Konzentration (Na_{STD}) einer Ionenart und einer Leitfähigkeit entsprechend einem bekannten Äquivalent-Hämatokritwert (H_A);
- 6) eine Einrichtung (130) zum Ableiten eines Signals entsprechend einem vorläufigen Proben-Hämatokritwert (H_x) aus dem Proben-Leitfähigkeits (R_x)-Signal, bezüglich dem Standard-Leitfähigkeits-Signal (R_A) und dem Standard-Äquivalent-Hämatokritwert (H_A); und
- 30 7) eine Einrichtung (130) zum Abgleichen des vorläufigen Proben-Hämatokritwerts (H_x) bezüglich dem Standard- und dem Proben-Ionenkonzentrations-Signal und der bekannten Standard-Ionenkonzentration (Na_{STD}) (Fig. 2, 12, 13).
- 35 10. Vorrichtung nach Anspruch 9, gekennzeichnet durch eine Einrichtung zum Speichern entweder des Proben- oder des Standard-Leitfähigkeits-Signals und eine Einrichtung zum Vergleichen der Leitfähigkeits-Signale mit dem bekannten Standard-Äquivalent-Hämatokritwert (H_A) zur Erzeugung eines Signals entsprechend dem vorläufigen Proben-Hämatokritwert (H_x).
- 40 11. Vorrichtung nach Anspruch 10, gekennzeichnet dadurch, daß die Einrichtung (130) zum Abgleichen des vorläufigen Proben-Hämatokritwert (H_x)-Signals besitzt eine Einrichtung zum Speichern entweder des Standard- oder des Proben-Ionenkonzentrations-Signals und Vergleichen der Konzentrations-Signale mit dem bekannten Standard-Ionenkonzentrations (Na_{STD})-Wert.
- 45 12. Vorrichtung nach Anspruch 9, gekennzeichnet durch mindestens zwei Standard-Lösungen (pH_A , pH_B) mit jeweils einer Leitfähigkeit entsprechend einem bekannten Äquivalent-Hämatokritwert (H_A) und einer bekannten Ionenkonzentration (Na_{STD}).
- 50 13. Vorrichtung nach Anspruch 9, gekennzeichnet dadurch, daß die Ionenart Na^+ oder Cl^- ist.
14. Vorrichtung nach Anspruch 9, gekennzeichnet dadurch, daß die Einrichtung zum Erzeugen des Leitfähigkeits-Signals besitzt: Elektroden (115, 116) im Strömungsweg, eine Konstantstrom-Wechselspannungs-Schaltung (118), gekoppelt an die Elektroden (115, 116) über einen Übertrager (120, 121), und eine Einrichtung zum Erfassen der Impedanz der Wechselspannungs-Schaltung (118) (Fig. 12).
- 55 15. Vorrichtung nach Anspruch 14, gekennzeichnet dadurch, daß die Einrichtung zum Erzeugen des Leitfähigkeits-Signals besitzt:
- 1) einen ersten Übertrager (120) zum Koppeln der Wechselspannungs-Schaltung (118) an die Elek-

- troden (115, 116);
 2) einen zweiten Übertrager (121) zum Unterhalten von Konstantstrom in der Wechselspannungsschaltung (118); und
 3) eine Einrichtung (210), die eine Schleife bildet, geschaltet zwischen die Elektroden (115, 116), und mit einer Einrichtung, geschaltet zwischen die Elektroden (115, 116) und den zweiten Übertrager (121), zum Kompensieren inneren kapazitiven Widerstands an der Elektroden/Proben-Grenzfläche (Fig. 12).
16. Vorrichtung nach Anspruch 15, gekennzeichnet dadurch, daß die Einrichtung zur Abgabe eines Signals der Konzentration einer Ionenart besitzt eine Ionenart-sensitive Elektrode (37, 39, 41), angeordnet im Strömungsweg und angeschlossen über eine elektrische Schaltung an den Eingang eines Multiplexers (183), die Impedanz-erfassende Einrichtung auch an den Eingang des Multiplexers (183) angeschlossen ist, der eine Ausgangsschaltung besitzt, angeschlossen über einen Analog-Digital-Umsetzer (188) an eine Einrichtung (130) zum Speichern und Vergleichen von Signalen, und an die Einrichtung (130) zum Abgleichen der Proben-Leitfähigkeit (Fig. 12).
17. Verwendung eines Kontroll - Lösungs - Kits zum Überprüfen der Vorrichtung nach einem der Ansprüche 10 - 13,
 - der einen vorläufigen Hämatokrit-Wert einer Blut-Probe bestimmt durch
 - Bestimmen der Proben-Leitfähigkeit (R_x) und
 - Abgleichen des vorläufigen Werts bezüglich einem Proben-Ionenart-Konzentrations (Na_x) -Wert,
 mit
 - wäßriger Lösung
 mit
 - der Ionenart und
 - einem Ionenaktivitäts-Verstärker, und
 mit
 - einer Ionenaktivität entsprechend einer bekannten Konzentration der Ionen und
 - einer Leitfähigkeit entsprechend einem bekannten Äquivalent-Hämatokritwert,
 - wobei die Ionenart-Konzentration und der Hämatokritwert
 - in physiologisch normalen Bereichen liegen.
18. Verwendung nach Anspruch 17, gekennzeichnet dadurch, daß
 - die Ionenart
 - Na^+ oder Cl^- ist.
19. Verwendung nach Anspruch 17 oder 18, gekennzeichnet dadurch, daß
 - der Ionenaktivitäts-Verstärker
 - ein Polyol ist.
20. Verwendung nach Anspruch 19, gekennzeichnet dadurch, daß
 - das Polyol ausgewählt ist aus
 - Glycerin (1,2,3-Propantriol) und Polyalkyl-Ethylenglykol (1,2-Ethandiol, "Glykol").

Revendications

1. Procédé de détermination de la valeur de l'hématocrite d'un échantillon sanguin par mesure de la conductivité de l'échantillon, caractérisé par
 a) la fourniture d'un appareil comprenant un passage d'écoulement liquide (fig. 2), des moyens (115, 116, fig. 12) dans ledit passage d'écoulement pour produire un signal électrique représentant la conductivité électrique d'un liquide dans le passage, et des moyens (37, 39, 41) dans le passage d'écoulement pour obtenir un signal électrique représentant la concentration d'un moins une espèce ionique dans le liquide dudit passage d'écoulement;
 b) l'introduction d'une solution d'étalonnage (pH_A , pH_B) dans le passage d'écoulement ayant une concentration connue (Na_{STD}) de ladite espèce ionique et une conductivité représentant une valeur

- d'hématocrite équivalent connue (H_A), l'obtention d'un signal représentant ladite conductivité (R_A) de la solution d'étalonnage, l'obtention d'un signal représentant ladite concentration connue (Na_{STD}) de l'espèce ionique;
- 5 c) avant ou après l'introduction de la solution d'étalonnage, l'introduction de l'échantillon dans ledit passage d'écoulement et l'obtention d'un signal électrique représentant la conductivité (R_x) de l'échantillon et d'un signal électrique représentant la concentration (Na_x) de l'espèce ionique de l'échantillon;
- d) la déduction d'une valeur provisoire (H_x) de l'hématocrite de l'échantillon sensible au signal de la conductivité (R_x) de l'échantillon, par rapport audit signal de conductivité (R_A) d'étalonnage et à ladite valeur (H_A) d'hématocrite équivalente d'étalonnage connue; et
- 10 e) la correction de ladite valeur provisoire (H_x) de l'hématocrite de l'échantillon par rapport auxdits signaux de concentration ionique de l'échantillon et d'étalonnage et à ladite valeur connue (Na_{STD}) de concentration des ions (fig. 2, 12, 13).
2. Procédé selon la revendication 1, caractérisé par la fourniture, de temps à autre, d'une validation externe dudit appareil par introduction dans ledit passage d'écoulement d'une solution de contrôle ayant une activité ionique correspondant à une concentration d'espèce chimique connue, et une conductivité représentant un niveau connu d'hématocrite équivalent, ladite concentration d'espèce ionique et ledit niveau d'hématocrite étant dans des domaines physiologiquement normaux.
- 15 3. Procédé selon la revendication 2, caractérisé en ce que ladite solution de contrôle comprend un agent augmentant l'activité ionique.
- 20 4. Procédé selon la revendication 3, caractérisé en ce que ledit agent augmentant l'activité ionique est un polyol.
- 25 5. Procédé selon la revendication 4, caractérisé en ce que ledit polyol est choisi parmi le glycérol et les polyalkylglycols.
6. Procédé selon la revendication 1 ou 2, caractérisé en ce que ladite étape d'obtention de la conductivité comprend:
- 30 a) la fourniture d'électrodes (115, 116) dans ledit passage d'écoulement couplées à un circuit (118) en courant alternatif à courant constant par l'intermédiaire d'un transformateur (120, 121);
- b) l'application auxdites électrodes (115, 116) d'un signal en courant alternatif provenant dudit circuit (118) par l'intermédiaire dudit transformateur (120, 121); et
- 35 c) la détection de l'impédance réfléchie dans ledit circuit en courant alternatif (118) (fig. 12).
7. Procédé selon la revendication 1 ou 2, caractérisé par la réalisation des étapes suivantes dans un ordre quelconque:
- a) obtention desdits signaux électriques représentant la conductivité d'étalonnage (R_A) et la concentration ionique d'étalonnage (Na_{STD});
- 40 b) stockage des signaux représentant ladite valeur d'hématocrite équivalent d'étalonnage connue (H_A) et ladite valeur de concentration ionique d'étalonnage connue (Na_{STD});
- c) obtention desdits signaux électriques représentant la concentration ionique (Na_x) de l'échantillon et la concentration ionique d'étalonnage (Na_{STD});
- 45 d) comparaison desdits signaux de concentration ionique de l'échantillon et d'étalonnage par rapport audit signal stocké de la valeur de concentration d'étalonnage (Na_{STD}) connue pour déduire un signal représentant la valeur de concentration ionique (Na_x) de l'échantillon;
- e) comparaison desdits signaux de conductivité de l'échantillon et d'étalonnage par rapport audit signal stocké de la valeur d'hématocrite d'étalonnage (H_A) pour déduire un signal représentant ladite valeur provisoire (H_x) de l'hématocrite de l'échantillon;
- 50 f) correction dudit signal de la valeur provisoire (H_x) de l'hématocrite de l'échantillon par rapport audit signal de concentration ionique (Na_x) de l'échantillon et audit signal stocké de la valeur de concentration ionique d'étalonnage (Na_{STD}).
8. Procédé selon l'une quelconque des revendications précédentes, caractérisé en ce que ladite espèce ionique est Na^+ ou Cl^- .
- 55 9. Appareil (10) pour déterminer la valeur de l'hématocrite d'un échantillon sanguin comprenant un moyen pour mesurer la résistivité dudit échantillon, caractérisé par

- 1) un moyen pour fournir un passage d'écoulement liquide (fig. 2);
 2) un moyen (115, 116) dans ledit passage d'écoulement pour fournir un signal électrique représentant la conductivité du liquide passant dans ledit passage d'écoulement;
 3) un moyen (37, 39, 41) dans ledit passage d'écoulement pour fournir un signal représentant la concentration d'une espèce ionique dans le liquide passant dans ledit passage d'écoulement;
 4) un moyen (24) pour introduire ledit échantillon sanguin dans ledit passage d'écoulement pour obtenir un signal représentant la conductivité (R_x) de l'échantillon et la concentration (Na_x) de l'espèce ionique de l'échantillon;
 5) un moyen (53, 53') pour introduire dans ledit passage d'écoulement une solution d'étalonnage ayant une concentration connue (Na_{STD}) en une espèce ionique et une conductivité représentant une valeur d'hématocrite équivalente connue (H_A);
 6) un moyen (130) pour déduire un signal représentant une valeur provisoire (H_x) de l'hématocrite de l'échantillon à partir du signal de conductivité (R_x) de l'échantillon, par rapport au signal (R_A) de conductivité d'étalonnage et à ladite valeur (H_A) d'hématocrite équivalente d'étalonnage; et
 7) un moyen (130) pour corriger ladite valeur provisoire (H_x) de l'hématocrite de l'échantillon par rapport auxdits signaux de concentration ionique d'étalonnage et de l'échantillon et à ladite concentration ionique d'étalonnage (Na_{STD}) connue (fig. 2, 12, 13).
10. Appareil selon la revendication 9, caractérisé par un moyen pour stocker ledit signal de conductivité de l'échantillon ou ledit signal de conductivité d'étalonnage, et un moyen pour comparer lesdits signaux de conductivité par rapport à ladite valeur (H_A) de l'hématocrite équivalente d'étalonnage connue pour produire un signal représentant ladite valeur provisoire (H_x) de l'hématocrite de l'échantillon.
11. Appareil selon la revendication 10, caractérisé en ce que ledit moyen (130) pour corriger ledit signal de la valeur provisoire (H_x) de l'hématocrite de l'échantillon comprend un moyen pour stocker ledit signal de concentration ionique d'étalonnage ou ledit signal de concentration ionique de l'échantillon et pour comparer lesdits signaux de concentration par rapport à ladite valeur de concentration ionique d'étalonnage (Na_{STD}) connue.
12. Appareil selon la revendication 9, caractérisé par au moins deux solutions d'étalonnage (pH_A , pH_B), ayant chacune une conductivité indiquant une valeur d'hématocrite équivalente (H_A) connue et une concentration ionique (Na_{STD}) connue.
13. Appareil selon la revendication 9, caractérisé en ce que ladite espèce ionique est Na^+ ou Cl^- .
14. Appareil selon la revendication 9, caractérisé en ce que ledit moyen produisant un signal de conductivité comprend: des électrodes (115, 116) dans ledit passage d'écoulement, un circuit en courant alternatif (118) à courant constant couplé auxdites électrodes (115, 116) par l'intermédiaire d'un transformateur (120, 121), et un moyen pour détecter l'impédance réfléchie dans ledit circuit en courant alternatif (118) (fig. 12).
15. Appareil selon la revendication 14, caractérisé en ce que ledit moyen produisant un signal de conductivité comprend:
 1) un premier transformateur (120) pour coupler ledit circuit en courant alternatif (118) auxdites électrodes (115, 116);
 2) un second transformateur (121) pour maintenir un courant constant dans ledit circuit en courant alternatif (118); et
 3) un moyen (210) établissant une boucle, branché entre lesdites électrodes (115, 116), et comprenant un moyen branché entre lesdites électrodes (115, 116) et ledit second transformateur (121) pour compenser la capacitance inhérente à l'interface électrode/échantillon (fig. 12).
16. Appareil selon la revendication 15, caractérisé en ce que ledit moyen pour fournir un signal de la concentration d'une espèce ionique comprend une électrode (37, 39, 41) sensible à l'espèce ionique placée dans ledit passage d'écoulement et reliée par l'intermédiaire d'un circuit électrique à l'entrée d'un multiplexeur (183), ledit moyen détecteur d'impédance étant aussi relié à l'entrée dudit multiplexeur (183), ledit multiplexeur (183) ayant un moyen formant sortie relié par l'intermédiaire d'un convertisseur analogique-numérique (188) à un moyen (130) pour stocker et comparer les signaux, et audit moyen (130) pour corriger la conductivité de l'échantillon (fig. 12).

17. Utilisation d'un Ensemble de solution de contrôle pour évaluer l'appareil selon l'une quelconque des revendications 10 à 13,
- qui détermine un niveau provisoire pour l'hématocrite d'un échantillon sanguin par
- détermination de la conductivité (R_x) dudit échantillon et
- correction dudit niveau provisoire par rapport à un niveau de concentration (Na_x) d'une espèce ionique de l'échantillon,
comprenant
- une solution aqueuse
comprenant
- ladite espèce ionique et
- un agent augmentant l'activité ionique, et ayant
- une activité ionique correspondant à une concentration connue audit ion et
- une conductivité représentant une valeur l'hématocrite équivalent connue,
- ladite concentration de l'espèce ionique et ladite valeur d'hématocrite étant
- dans des gammes physiologiquement normales.
18. Utilisation selon la revendication 17, caractérisé en ce que
- ladite espèce ionique est
- Na^+ ou Cl^- .
19. Utilisation selon la revendication 17 ou 18, caractérisé en ce que
- ledit agent augmentant l'activité ionique est
- un polyol.
20. Utilisation selon la revendication 19, caractérisé en ce que
- ledit polyol est choisi parmi
- le glycérol et les polyalkylglycols.

FIG 1

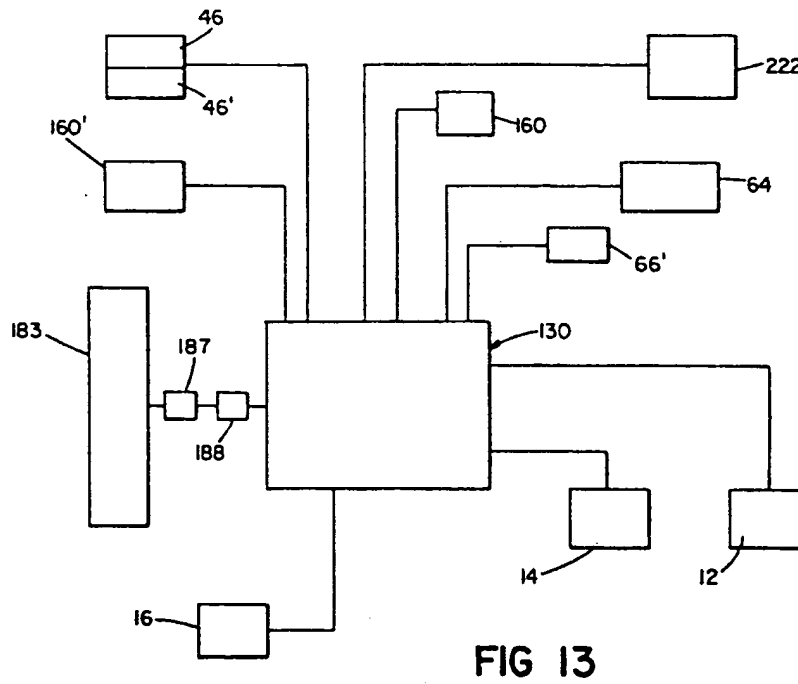
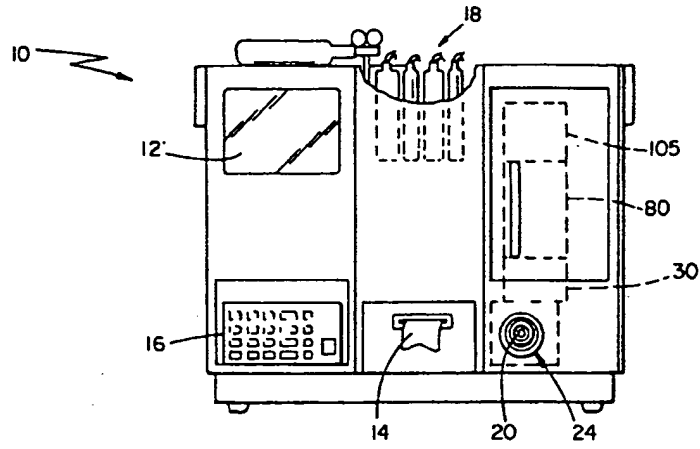

FIG 13

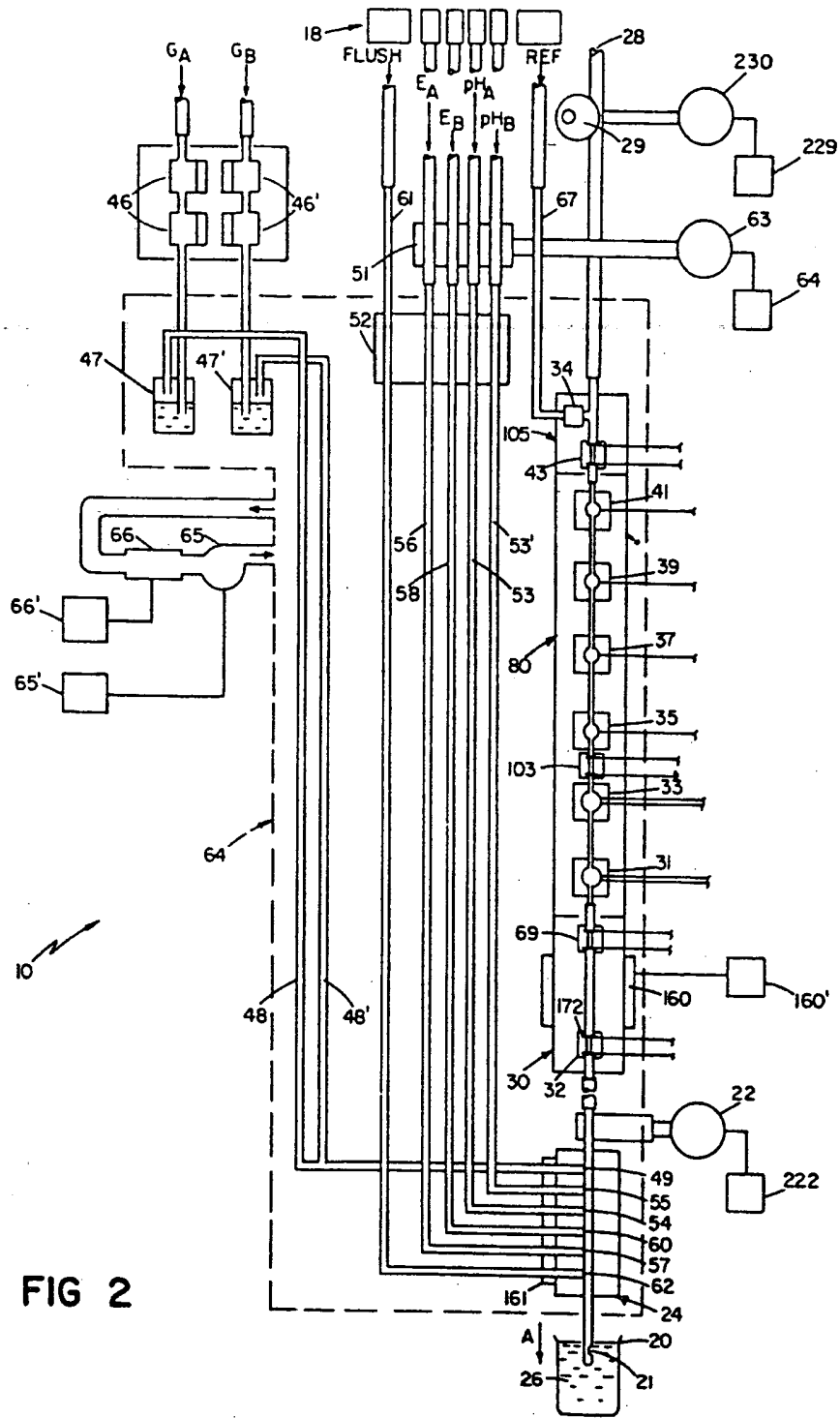

FIG 2

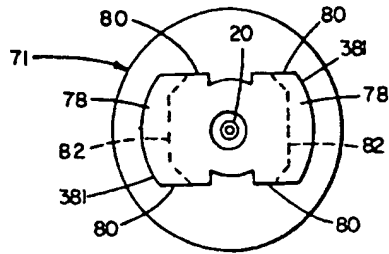

FIG 4

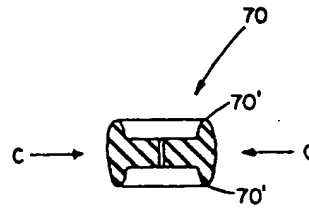

FIG 4A

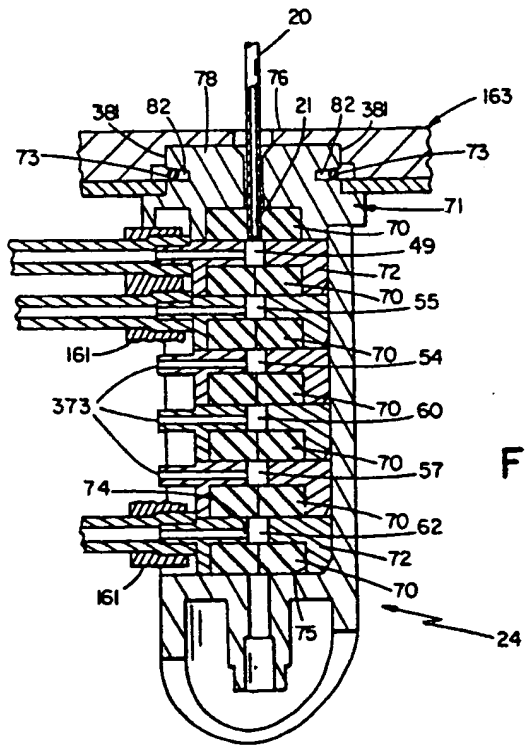

FIG 3

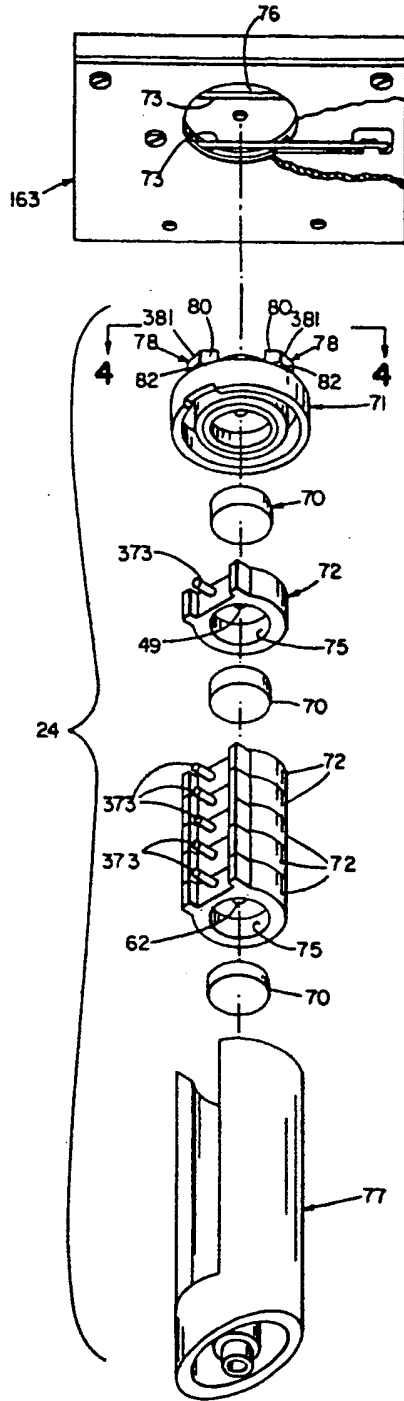

FIG 5

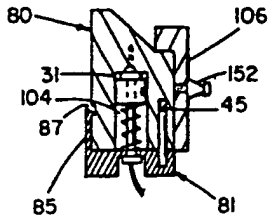

FIG 7

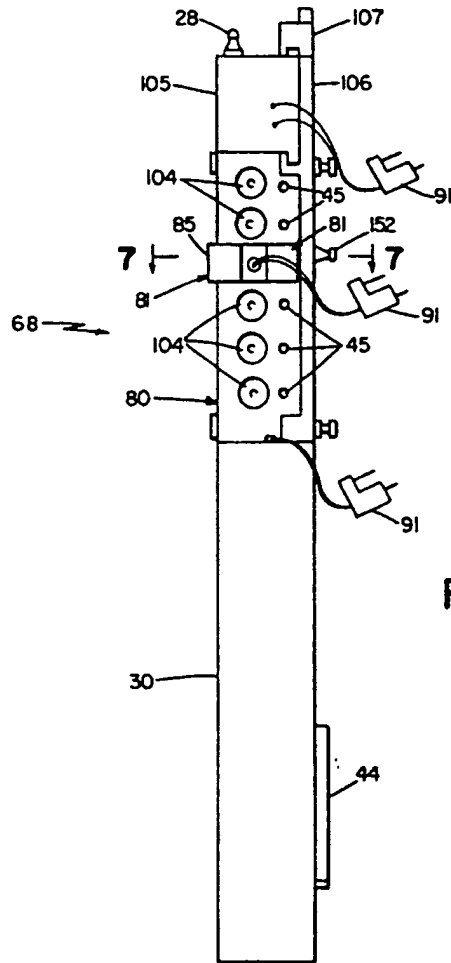

FIG 6

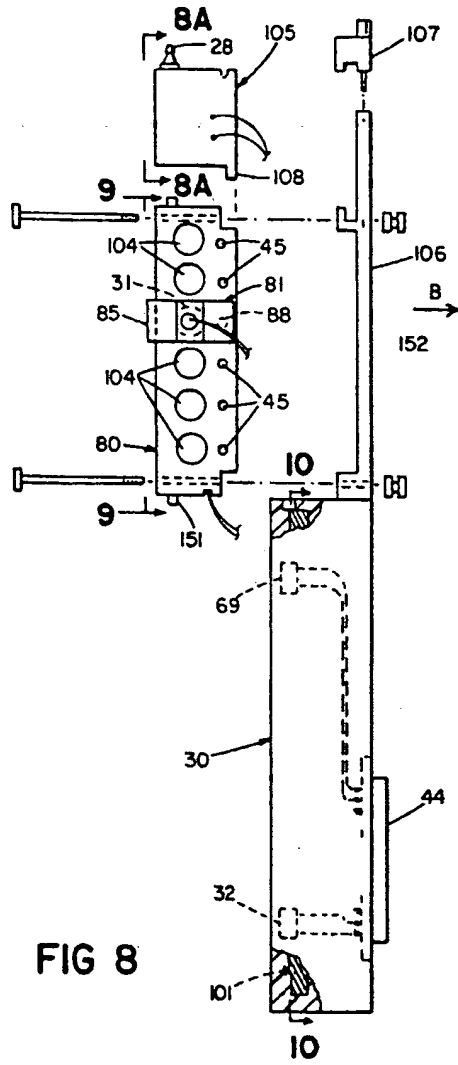

FIG 8

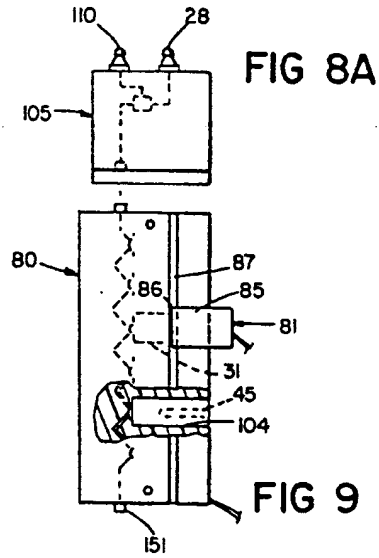
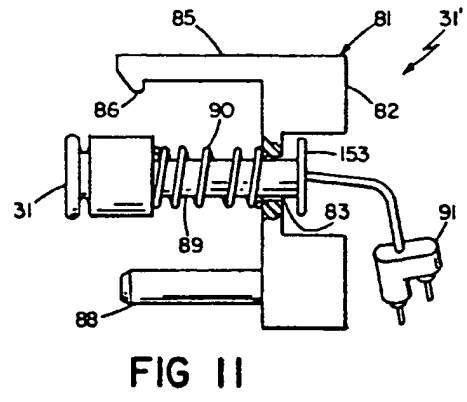
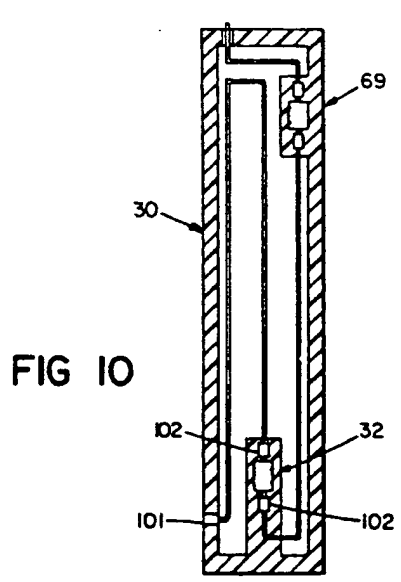

FIG 8A

FIG 9



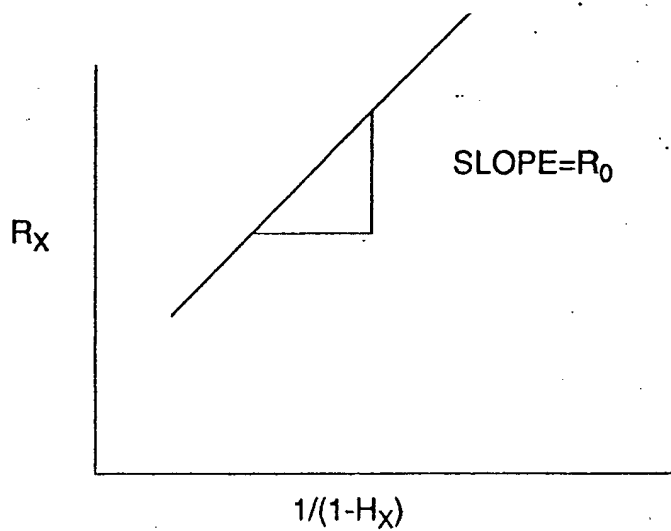

FIG 12A

**This Page is Inserted by IFW Indexing and Scanning
Operations and is not part of the Official Record**

BEST AVAILABLE IMAGES

Defective images within this document are accurate representations of the original documents submitted by the applicant.

Defects in the images include but are not limited to the items checked:

- BLACK BORDERS**
- IMAGE CUT OFF AT TOP, BOTTOM OR SIDES**
- FADED TEXT OR DRAWING**
- BLURRED OR ILLEGIBLE TEXT OR DRAWING**
- SKEWED/SLANTED IMAGES**
- COLOR OR BLACK AND WHITE PHOTOGRAPHS**
- GRAY SCALE DOCUMENTS**
- LINES OR MARKS ON ORIGINAL DOCUMENT**
- REFERENCE(S) OR EXHIBIT(S) SUBMITTED ARE POOR QUALITY**
- OTHER:** _____

IMAGES ARE BEST AVAILABLE COPY.

As rescanning these documents will not correct the image problems checked, please do not report these problems to the IFW Image Problem Mailbox.

This Page Blank (uspto)